



# Jaytech

*Professional Garage Door Openers*



## **WARNING**

Please read this manual carefully before installation and use. The installation of your new door opener should be carried out by a technically qualified person. Attempting to install or repair the door opener without suitable technical qualification may result in **severe personal injury**, death and / or property damage.

# CONTENTS

Important safety recommendations .....	1 -
Basic function introduction .....	3 -
Installation recommendations .....	3 -
Installation .....	4 -
Installation (steel track) .....	5 -
Track assembly (optional) .....	6 -
Battery backup assembly (optional) .....	7 -
Basic function settings .....	7 -
Special functions, optional parts introduction and application .....	11 -
Manual disengagement .....	12 -
Maintenance .....	13 -
Final notes .....	13 -
Important information for the user .....	13 -
Packing list .....	14 -
Technical specifications .....	14 -
Common faults & solutions .....	15 -
Warranty information .....	14 -
Warranty form .....	14 -

## Important safety recommendations

**FAILURE TO COMPLY WITH THE FOLLOWING SAFETY RECOMMENDATIONS MAY RESULT IN SERIOUS PERSONAL INJURY, DEATH AND / OR PROPERTY DAMAGE. WE STRONGLY RECOMMEND INSTALLATION IS COMPLETED BY A TRAINED TECHNICIAN.**

**PLEASE READ CAREFULLY AND ADHERE TO ALL SAFETY AND INSTALLATION RECOMMENDATIONS.**

This opener is designed and manufactured to meet Australian Standards AS/NZS 60335.2.95:2012 and AS/NZS 60335.1:2011 when installed correctly.

Unqualified personnel or those persons, who do not know the occupational health and safety standards being applicable to automatic garage doors, must in no circumstances carry out installations or implement systems.

Persons who install or service this equipment without observing all the applicable safety standards will be responsible for any damage, injury, expense or claim as a result of failure to install the system correctly and in accordance with the relevant safety standards.

For additional safety we recommend the inclusion of a Photo Beam System. Although the opener incorporates a pressure sensitive Safety Obstruction Force system, the addition of a Photo Beam System will greatly enhance the operating safety of an automatic garage door.

Make sure that the garage door is fully open & stationary before driving in or out of the garage.

Make sure the garage door is fully closed & stationary after operation.

Keep hands and loose clothing away from the opener and garage door during operation.

The Safety Obstruction Force System is designed to work on STATIONARY objects only. Serious personal injury, death and / or property damage may occur if the garage door contacts a moving object.

Do not allow children to play with the appliance or its controls.

**WARNING:** The manual release cord is designed only to disengage the drive carriage. It should never be used to pull the door upwards or downwards.

Take care when operating the manual release since an open door may fall rapidly due to weak or broken springs or being out of balance. If in doubt call a Service Technician

Never operate an automatic garage door unless it is fully visible.

Watch the moving door and keep people away until the door is completely open or closed.

Each month check that the opener reverses when the door contacts a 40 mm high solid object placed on the floor. Adjust force settings if necessary and recheck. An incorrect adjustment may present a hazard.

This garage door opener shall be supplied with a label suitable for permanent fixing with a warning sign advising to keep children away from a moving garage door, having a height of at least 60 mm. Periodically check that this warning is still in place.

This garage door opener is supplied with an information card that should be attached to the manual release cord detailing the manual release procedure.

This garage door opener should be disconnected from its power source during cleaning and maintenance.

Before installing this automatic opener, check that the door is in good mechanical condition.

Install the actuating member for the manual release at a height less than 1.8m.

Install any fixed control at a height of at least 1.5 m and within sight of the door but away from moving parts.

After installation, ensure that the mechanism is properly adjusted and that the drive reverses or the object can be freed when the door contacts a 40 mm high object.



Waste electrical products should not be disposed of with household waste. Please recycle where facilities exist. Check with your local authority or for recycling advice.

## Basic function introduction

1. PTC Fuse inside the transformer, to prevent overload.
2. "Operate" button on the display board.
3. Copper worm gear inside the motor. With high impact resistant strength.
4. Multiple highlight LED lighting.
5. Multifunction external terminal can be used to connect various external devices such as photo beams, push button switches, WIFI smart controllers & flashing lights.
6. LED display for ease of use and adjustment.
7. Rolling code transmitters, with billions of possible codes for security.
8. Soft start, soft stop operation minimizes start-up load on garage door opener and garage door and ensures low noise, smooth operation.
9. Micro intelligent mapping. During operation, the opener utilizes real-time detection of resistance to ensure precise positioning and force monitoring.
10. Adjustable time auto close function.
11. Self-locking function so the garage door can still be locked manually in the event of a power outage.
12. 1200Nm lifting force.
13. Safety reverse function. The door will reverse to the fully open position when encountering a solid obstacle on closing cycle and stop when encountering excess resistance on the open cycle. These values are adjustable from the menu.
14. Backup battery interface available in case of power failure or low voltage.
15. Original opening & closing force self-learning.
16. Low-voltage protection & cut out.
17. Strong metal chassis.
18. Re-enforced belt drive

## Installation recommendations

Legal requirements and standards must be adhered to, please take notice of the following points to ensure maximum safety and reliability of your new garage door opener.

Before installation, check the surrounding environment. Carefully evaluate any hazards which may be present.

**Remember** - this unit has main voltage running through it (electrocution hazard, fire hazard).

Take care with the control unit; the parts may be subject to damage if the control unit is abused.

Make sure that you have the necessary and appropriate tools, equipment and wear PPE at all times.  
 Read all the instructions thoroughly, and make sure they are understood before attempting to install the opener.  
 Before starting the installation, carefully analyze all the risks relating to automating the door. Verify that the door is in a sound condition and that the mechanisms are in good working order. Observe the safety margins and minimum distances.

**Important note: It is thoroughly recommended that the installation of a garage door opener be carried out by a trained Technician. DIY is an option but proceed at your own risk.**

## Installation

- 1) Read the instructions carefully.
- 2) Make sure the door structure is solid and suitable to be motor driven.
- 3) Make sure the door runs smoothly in manual operation before fitting an automatic opener.
- 4) The door must be properly balanced and must be easily lowered and raised by hand.

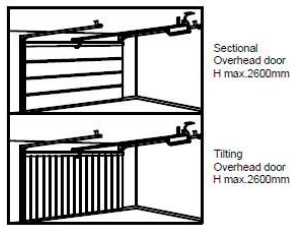

Fig. 1

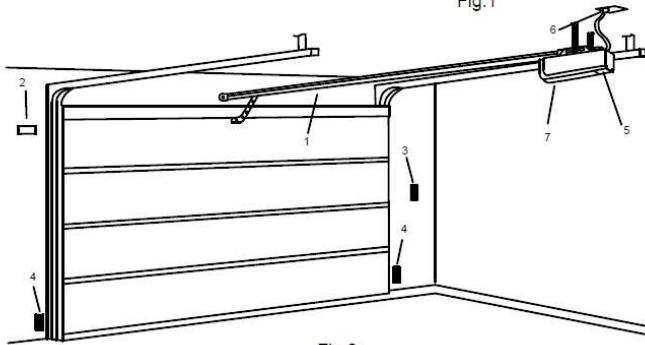
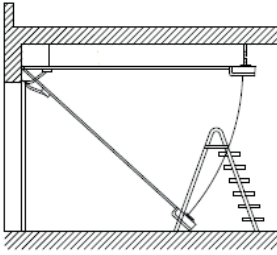

Fig. 2

Referring to Fig. 2 for recommended installation

- |                                  |                 |
|----------------------------------|-----------------|
| 1) Track                         | 5) Menu buttons |
| 2) 24V DC flash light (optional) | 6) Power socket |
| 3) Wall switch (optional)        | 7) Door opener  |
| 4) Photo beam (optional)         |                 |



**Fig.3**

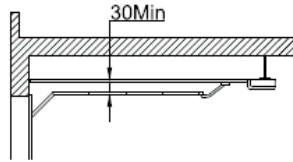

**Fig.4**

Maintain a minimum gap of 30mm between the top panel and the bottom of the rail (Fig. 4).

Make sure the track is horizontal. Place a spirit level on the track if required. Make sure the connection of the hanging bracket is firm and secure (Fig.5, F)

**Warning:** Make sure the opener is affixed to a solid mounting point or joist and not to plasterboard. Failure to have a safe and secure fixing can lead to opener falling and may cause serious damage and/or personal injury.

## Installation (steel track)

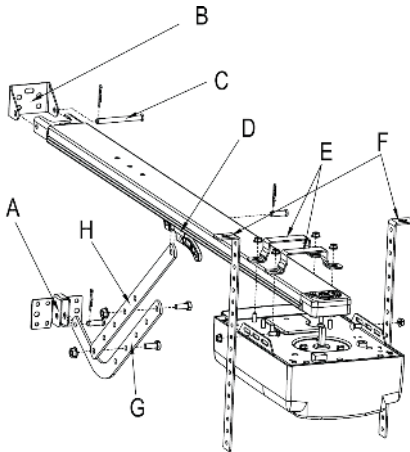

**Fig.5**

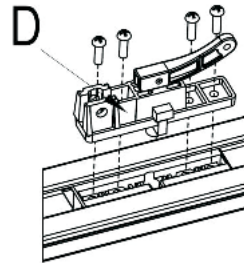

**Fig.6**

1. Fix the wall bracket(B) to the wall 2cm-15cm above the torsion shaft or spring and central to the door.
2. Fix the steel track to the wall bracket using axis pin  $\Phi 8 \times 80$  (C) and cotter pin. (Fig. 5)
3. Fix garage door opener to the track using 2 x U brackets supplied(E). Then fasten using M6 nuts x4 supplied.
4. Fix the hanging bracket(F) to the edge of the opener as in Fig. 5 using M6x16 carriage bolts and/or rail hanger supplied. If using rail hanger, bend tabs down after fixing to the track to secure.

5. Fix the opener to the ceiling joist or suitable support using fasteners suitable for the fixing material (not supplied) and observe the fastener manufacturers guidelines, uses and ratings.
6. Fix the door bracket(A) to the top edge of the door in the middle and under the wall bracket using suitable fasteners (not supplied)
7. Connect the bent arm(G) to the door bracket using the  $\Phi 8 \times 25$  axle pin and cotter pin as shown in Fig.5.
8. Install the shuttle(D) to the track using the 4x M6x20 screws supplied (Fig.6), tie the clutch cord. Connect the straight arm(H) to the clutch using the  $\Phi 8 \times 25$  axle pin as shown in Fig.5. Affix manual release procedure instruction card to clutch cord/manual release cord.
9. Connect the bent arm and straight arm using M8 outer hexagon bolts and nuts supplied (before connecting, adjust to a suitable length)
10. Release the clutch, try to open and close the door by hand. Make sure there is no contact between door panel and track.
11. Connect the opener to power.

**Notice:** Make sure the opener's voltage is in accordance with the local voltage. Connect the opener to a properly earthed power supply.

## Track Assembly – Only required for segmented rails

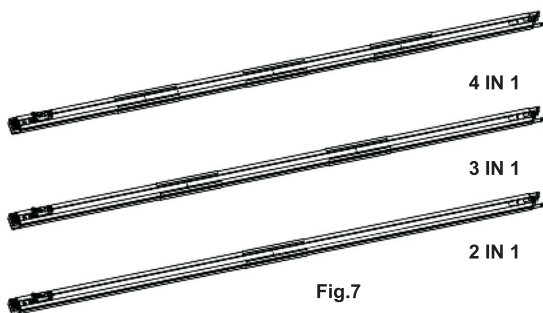

Confirm the type of segmented rail you have according to Fig7.

Skip this step if you have a 1piece rail.

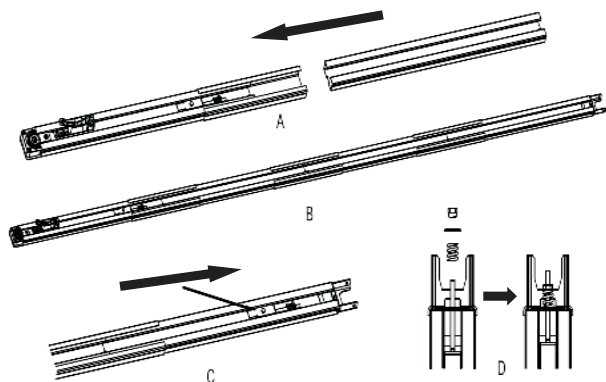

Install the rails according the steps in Fig8:

A. Connect the rails by the sleeve;

B. Follow the steps in the picture to connect the rails

C. Move the pulley to the top end of the rail after the rails are connected

D. Stretch the screw bolt of the pulley into the hole on the rail. Install the spring, washer, and adjusting nut. Adjust the nut to a suitable position, the installation of the rail is complete.

Fig.8

## Battery backup Assembly (optional)

Assemble the battery using battery bracket, washers and nuts supplied (Fig. 9, Fig.10). Connect the battery leads to the marked terminals on the internal PCB.

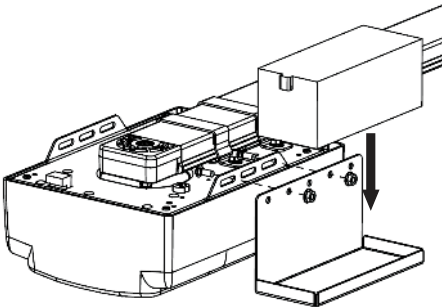

Fig.9

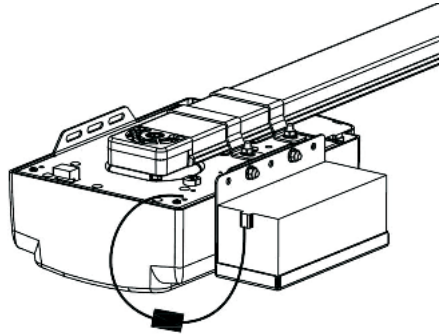

Fig.10

## Basic function settings

### 1. Matching the receiver and transmitter

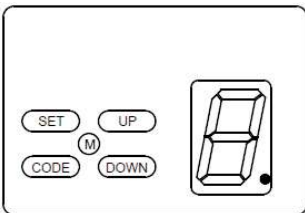

Fig. A

**(The opener is supplied with pre-coded transmitters.)**

**NOTE** – Later model openers may have 'S' in place of 'SET', 'C' in place of 'CODE', '+' in place of 'UP' and '-' in place of 'DOWN'

#### Coding Transmitters:

Press and hold "CODE" button for 1 second until the LED dot is illuminated (Fig A). Press a preferred button on transmitter once, the LED dot will extinguish, press the same button on the transmitter again.

The transmitter is now coded into the receiver.

Repeat the above steps to code more transmitters.

The receiver has the capacity to store 20 transmitters.

If the LED display flashes "F" and returns to standby mode (after you have pressed the "CODE" button), this indicates that the memory storage is full.

Follow the steps below to **delete all transmitters** that are stored in the receiver memory (in case of a full memory, lost or stolen transmitter)

Press and hold on "CODE" button for more than 8 seconds until the LED flashes "C", all the stored codes are deleted.

## 2. Travel limit setting Opening & closing force self-learning

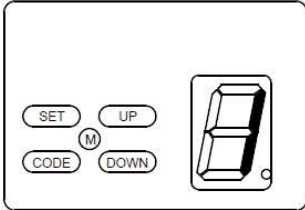

**NOTE** – Later model openers may have 'S' in place of 'SET', 'C' in place of 'CODE', '+' in place of 'UP' and '-' in place of 'DOWN'

Press and hold "SET" button for 3 seconds until the LED flashes "1". Press "SET" button again for 1 second. "1" should now display as steady (not flashing).

Adjust the open limit by pressing and holding the "UP" button. When the door is near it's intended open position release the button and fine-tune the open position by momentarily pressing the "UP" and "DOWN" to determine the final open limit position, then press "SET" button, the display will show "2"

**NOTICE** – Be sure not to set the open limit too far as this can cause the door to overtravel and come out of the tracks or torsion cables to become loose.

Now adjust the close limit by pressing and holding the "DOWN" button. When the door is near it's intended close position release the button and fine-tune the position by momentarily pressing the 'UP' and 'DOWN' buttons to determine the final close limit position, then press "SET"

*If the opener stops and displays "H" or "C", this indicates there's no hall signal or the opener is overloaded. Call a Service Technician.*

The opener will now operate a cycle automatically to remember the limit positions and the original opening & closing force, then return to standby mode.

During learning, if the door stops unusually, and flashes "H", "C", "O", "L" for 5 seconds, this indicates there's no hall signal, overload, overtime or an incorrect limit setting.

## 3. Safety reverse force adjustment

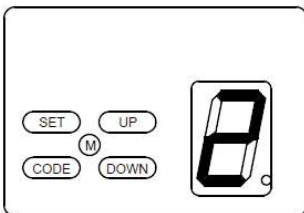

**NOTE** – Later model openers may have 'S' in place of 'SET', 'C' in place of 'CODE', '+' in place of 'UP' and '-' in place of 'DOWN'

Press and hold "SET" button for 3 seconds until the LED flashes "1". Press "UP" until LED flashes "2", then press "SET" button. The display is now in force adjustment mode. The LED displays the current set force value.

Press "UP" button to increase the force and "DOWN" button to decrease the force value. The maximum force is 9 and the minimum is 1. Press "SET" button to confirm, then the opener returns to standby mode.

The default setting of safety reverse force is 5.

**Warning** – Excessive or incorrect force settings can cause damage or personal injury. We recommend only authorized Technicians should adjust force values and a safety reverse test should be carried out after manually adjusting this setting.

**NOTE** – Later model openers may have 'S' in place of 'SET', 'C' in place of 'CODE', '+' in place of 'UP' and '-' in place of 'DOWN'

#### 4. Photo beam setting

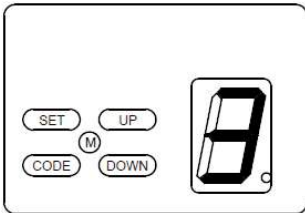

Press and hold "SET" button for 3 seconds until the LED flashes "1". Press "UP" button until the LED flashes "3", press "SET" button. The display is now in photo beam setting mode. The LED displays the current setting.

Press "UP" button, the LED displays "1", the Photo beam Function is enabled. Press "DOWN" button, the LED displays "0" to cancel this function. Press "SET" button to confirm. The opener returns to standby mode. The default setting of photo beam is "0".

**Notice: Default setting must be used when no photo beams are installed.**

#### 1. Auto-close setting

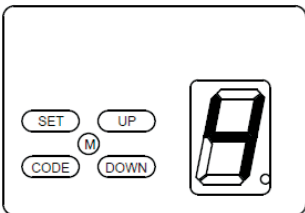

Press and hold "SET" button for 3 seconds until the LED flashes "1". Press "UP" or "DOWN" to increase or decrease, adjust the LED to flash "4", then press "SET" button to enter into auto-close setting, the LED displays the current setting.

Press "UP" or "DOWN" button to adjust the auto-close time. Press "UP" button once, the auto-close time will increase 1 minute, the maximum time is 9 minutes. Press "DOWN" button once, the auto-close time decreases by 1 minute. The auto-close function will be turned off when the LED displays "0". Press "SET" button to confirm, the opener returns to standby mode.

The auto-close function is only be available when the door is fully open and the photo beam function is on. The default setting is "0"

## 2. Lock door setting

(Only when the lock door function is available, the setting will proceed.

The "lock" key can not be matched)

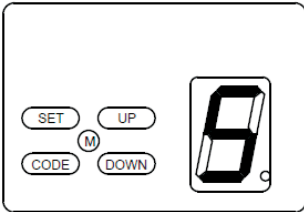

**NOTE** – Later model openers may have 'S' in place of 'SET', 'C' in place of 'CODE', '+' in place of 'UP' and '-' in place of 'DOWN'

Press and hold "SET" button for 3 seconds until the LED flashes "1". Press "UP" or "DOWN" button to increase or decrease. Adjust the LED to flash "5", press "SET" button to enter lock door setting. The LED displays the current setting.

Press "UP" button, the LED displays "1", the lock door function is on. Press "DOWN" button, the LED displays "0", the lock door function is off. Press "SET" button to confirm, the opener returns to standby mode.

When the lock door function is on and the door is fully closed, the opener will lock the door automatically. The door can only be opened by a transmitter after unlocking by the "lock" key(S2) on the transmitter. (If not unlocked by the S2 button on the transmitter, the light will flash twice when pressing the open key on the transmitter)

## 3. Half-open setting

(Only when the half-open function is available, the setting can proceed.

The half-open key on the transmitter can not be matched)

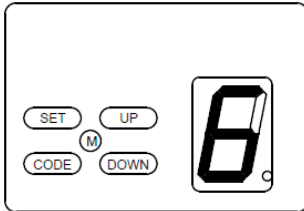

**NOTE** – Later model openers may have 'S' in place of 'SET', 'C' in place of 'CODE', '+' in place of 'UP' and '-' in place of 'DOWN'

Press and hold "SET" button for 3 seconds until the LED flashes "1". Press "UP" or "DOWN" button to increase or decrease. Adjust the LED to flash "6". Press "SET" button to enter half-open setting. The LED displays the current setting.

Press "UP" or "DOWN" button to increase or decrease. When the LED displays "1", the half-open height is 30cm. When the LED displays "2", the half-open height is 60cm. When the LED displays "3", the half-open height is 90cm. When the LED displays "0", the half-open function is off. Press "SET" button to confirm, the opener returns to standby mode.

If the half-open function is on, only when the door is fully closed, the door can half-open using the "S1" key on the transmitter. If the door is at another position, the "S1" key will not work.

## Special functions, optional parts introduction and application

### Photo beam/switch control connection (Fig.11, Fig.12)

#### Flashing light (optional)

There are corresponding interfaces for this function and provide 24v-35v flashing light voltage. Connect the flashing light with DC 24v-28v, currents $\leq$ 100mA. When using AC 220V power flashing lights, please match an adapter, and wiring as required (Fig.13).

#### Pass door (SD) protection (optional)

This function ensures that the door can't be opened unless a small pass door is closed. Connect according to Fig.14 .

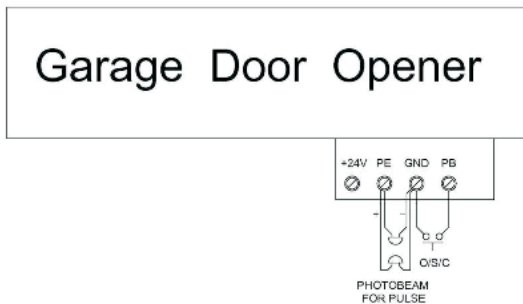
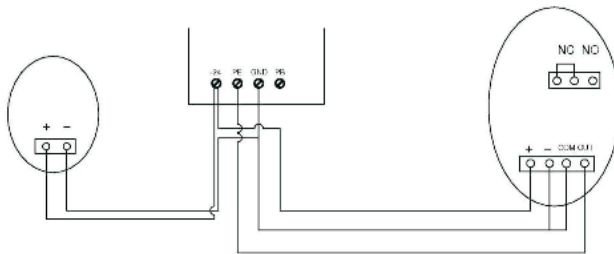

Fig. 11



Connection of photo beam/switch control

Fig. 12

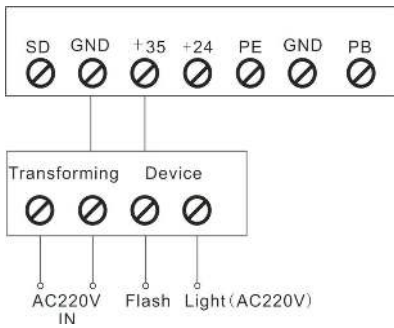

Fig. 13

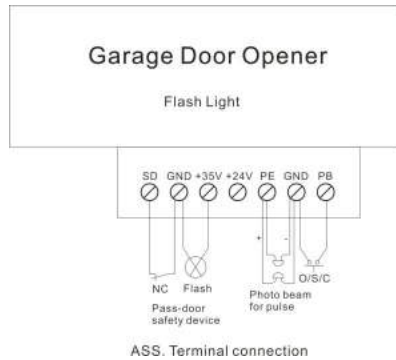

Fig. 14

## Manual disengagement

The opener is equipped with a manual release cord to disengage the shuttle and move the door by hand (Fig 15). Pull the handle downwards to disengage the shuttle, then lift the door by hand (do not try to lift the door with the manual release cord) To re-engage the shuttle simply flick the manual release cord backwards so that the attaching arm is facing towards the opener head unit then run opener in automatic mode or move door by hand until the trolley engages in the chain shuttle (spring loaded)

In some situations where no other access to the garage is possible, it is recommended that an external disengagement device or "coffin lock" should be fitted (Fig 16).

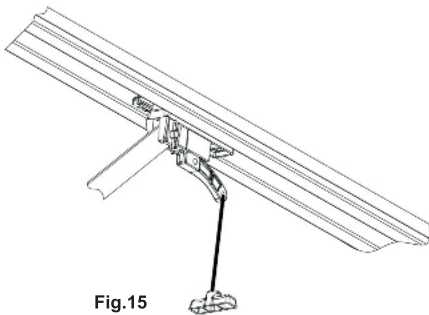

Fig.15

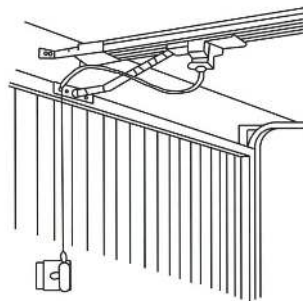

Fig.16

## Maintenance

The logic board is maintenance free.

Check the door is properly balanced, and all working parts are in good

working condition at least twice a year. **We recommend professional servicing annually to ensure the safety and longevity of your garage door and automatic opener.**

Check the reversing sensitivity and adjust if it is necessary.

Make sure that the safety devices are working effectively (photo beams, etc.)

**Notice: An inadequately maintained door can affect the life of the automatic opener due to incorrect loads and Can void the warranty.**

## Final notes

This manual is only to be used by technical persons who are qualified to carry out the installation.

It is important for the installer to show their clients correct operation of the opener including the procedure for manual disengagement.

Inform the owner about the need of regular maintenance, especially regarding a regular check of the safety and reversing devices and systems.

## Important information for the user

Once the opener has been installed, the user should be informed about the risks that can arise if it is used improperly. The user must avoid placing himself/herself in dangerous situations such as standing within the door's operating range when it is moving.

**IMPORTANT NOTE:** In the case of a malfunction the user must call an authorized Technician and should not attempt repair themselves.

## Packing list

Item	Quantity
Door opener	1
Track	1
Shuttle components kit	1
Transmitter	3
Rail hanger bracket	1
Manual & warning label	1
Warning label	1
Release cord (with caution paper and cord pendant)	1
Door bracket	1
Wall bracket	1
"U" bracket	2
Hanging bracket	2
Bent arm	1
Straight arm	1
Fastener kit	1

## Technical Specifications

Model	600N	800N	1000N	1200N
Rated door area	≤9.0 sqm	≤12.0 sqm	≤15.0 sqm	≤18.0 sqm
Rated lifting force	≤60 kgs	≤80 kgs	≤100 kgs	≤120 kgs
Rail	Steel / Aluminum	Steel / Aluminum	Steel / Aluminum	Steel / Aluminum
Drive	Chain / Belt	Chain / Belt	Chain / Belt	Chain / Belt
Motor	24V / 100W	24V / 120W	24V / 140W	24V / 160W
Input voltage	110V – 270V	110V – 270V	110V – 270V	110V – 270V
LED	24V / 14pcs LED bulbs			
Transformer	105°C Temperature detect switch			
Radio frequency	433.92 MHz			
Coding format	Rolling code (7.38x10 <sup>19</sup> combinations)			
Standard transmitter	3pcs			
Code storage capacity	20 different codes			
Working temperature	-40°C - +50°C			
Safety protection	Soft start & Soft stop, photo beam as optional, flashing light as optional			

## Common Fault & Solutions

Fault symptom	Fault cause	Solution
Opener doesn't operate	<ol style="list-style-type: none"> <li>1. Power supply</li> <li>2. Broken door spring</li> </ol>	<ol style="list-style-type: none"> <li>1. Check the power point is live.</li> <li>2. Disengage the opener and try to lift the door manually, if it feels heavy call a professional Technician.</li> </ol>
Opener doesn't work, LED displays "--"	Travel limits not set	Learn "UP" and "DOWN" travel limits again (Pg8)
The door will open but not close	Photo beam setting enabled with no photo beams present or an obstruction if photo beams are present.	<p>Check photo beam settings are correct (Pg9)</p> <p>If photo beams are installed, check for obstructions to the door travel.</p>
Open and close action is reversed	Reversed connection of the positive and negative of motor wire to the control board.	* Power off firstly, open the motor cover and reverse the positive and negative of motor wire on the control board. Re-set the travel limits.
Door auto reverse to full open before closing completely	Safety reverse function. Obstruction or door maintenance required	<ol style="list-style-type: none"> <li>1. Check for any obstructions</li> <li>2. Call a Professional Technician for maintenance</li> </ol>
Transmitter doesn't work	<ol style="list-style-type: none"> <li>1. Flat battery</li> <li>2. Antenna is loose or not well extended</li> <li>3. Signal interference</li> </ol>	<ol style="list-style-type: none"> <li>1. Replace battery</li> <li>2. Extend the antenna on the opener</li> <li>3. Eliminate signal interference (doorbell, baby monitor, alarm etc)</li> </ol>
Can't add new transmitters	<ol style="list-style-type: none"> <li>1. Memory is full</li> <li>2. New transmitters are not compatible with opener</li> </ol>	<ol style="list-style-type: none"> <li>1. Press and hold "CODE" button for more than 8 seconds until the LED flashes "C".</li> <li>2. Use only genuine Jaytech transmitters</li> </ol>
LED displays "C", opener does not work	<ol style="list-style-type: none"> <li>1. Motor plug wire is loose</li> <li>2. Control board is damaged</li> </ol>	<ol style="list-style-type: none"> <li>1. Re-insert motor plug wire</li> <li>2. Call professional Technician</li> </ol>
LED displays "I", opener does not work	1. Motor is damaged	1. Call professional Technician
LED displays "II" after opener operates several centimeters only	<ol style="list-style-type: none"> <li>1. Hall element wire plug is loose between hall element and control board.</li> <li>2. Hall element or control board is damaged</li> </ol>	<ol style="list-style-type: none"> <li>1. Check the wire plug</li> <li>2. Check the hall element</li> <li>3. Replace control board</li> </ol>

**Note: Only qualified Technicians should attempt repairs**

**PRODUCT WARRANTY** For 7 years from the date of installation, this product will be repaired, or replaced free of charge, if defective in material or workmanship.

**ADDITIONAL WARRANTY ON PARTS** Replacement parts for any defective parts on this product will be furnished, free of charge. Any costs for professional installation are included.

**WARRANTY RESTRICTION** This Garage Door Opener Warranty does not cover light bulbs or fuses, which are expendable items, or repair parts necessary because of operator abuse or negligence, including the failure to adjust and operate this garage door opener according to instructions contained in the owners' manual. This warranty also does not cover any problems caused by interference or impact damage and does not cover remote controls.

This warranty remains valid providing the door has been serviced at least every 3 years by any professional garage door company since the installation of this opener. Proof of service will be requested and failure to produce this may void your warranty. A 24 month warranty applies to the LED light board.

Warranty is void if damage or premature wear to the opener is sustained by a broken, unbalanced, worn or damaged garage door.

Original purchase receipt / Invoice is required to process a warranty claim.

If a technician is requested to attend and rectify the issue and it is reasonably deemed to be caused by other factors other than a product fault the customer agrees that they may be charged a call out fee, plus any parts required to complete the repair. **Liability – Australia only**

Under no circumstances shall the Seller be liable for consequential, incidental or special damages arising in connection with the use, or inability to use, the Unit. In no event shall the Seller's liability for damages or injury arising from breach of law or contract or for negligence, exceed the cost of repairing or replacing the Unit or refunding the purchase price of the Unit. Under Division 2 Part V of the Trade Practices Act, 1974, certain warranties and conditions (Implied Terms) are implied into contracts for the supply of goods or services if the goods or services are of a kind ordinarily acquired for personal, domestic or household use or consumption. Liability for breach of those Implied Terms cannot be excluded or limited and the limitations and exclusions above do not apply to the Implied Terms. Except for the Implied Terms and the warranties set out above, the Seller excludes all warranties and conditions implied by statute, at law, in fact or otherwise.

Our goods come with guarantees that cannot be excluded under the Australian Consumer Law. You are entitled to a replacement or refund for a major failure and compensation for any other reasonably foreseeable loss or damage. You are also entitled to have the goods repaired or replaced if the goods fail to be of acceptable quality and the failure does not amount to a major failure.

If you believe you have a faulty product you may submit a warranty request by contacting the company listed below.

Installation completed by \_\_\_\_\_

Date \_\_\_\_ / \_\_\_\_ / \_\_\_\_

Contact Details \_\_\_\_\_

Notes \_\_\_\_\_

Register your warranty online for faster service, product updates, special offers and service reminders

<https://www.jaytechopeners.com.au/warranty-registration/>

